

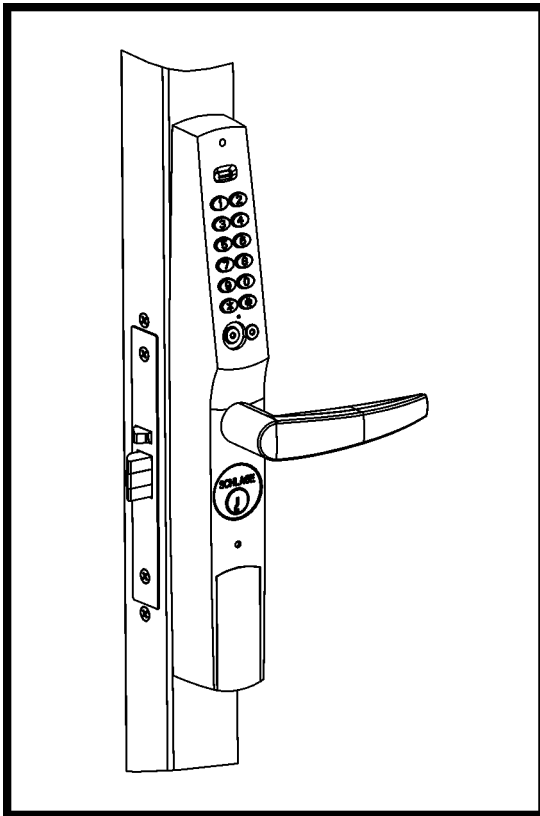

KING COBRA/KING COBRA-2 NARROW STILE SERIES

INSTALLATION MANUAL

KC918A/KC918A-2



KC938A/KC938A-2

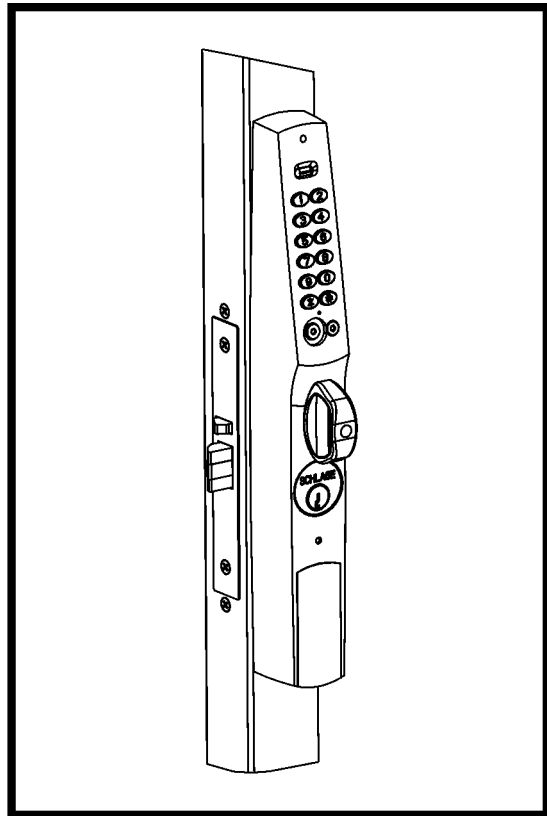

**Keypad Programmable and SNAP
Compatible Trim For 995 MF
Multi-Function NS Mortise Lock**



KC918A/KC918A-2, KC938A/KC938A-2 INSTALLATION

Contents of the Box

Confirming the Box Contents

The following items should be included in the box. If any of these items are missing, please contact the Technical Support Department for assistance.

4 "AAA" Batteries Included

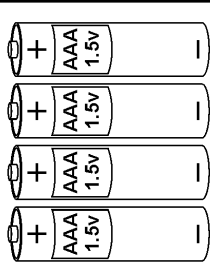

Optional Parts

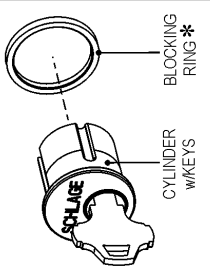

DOCUMENTS INCLUDED IN BOX:

- Installation Manual
- Programming Instructions

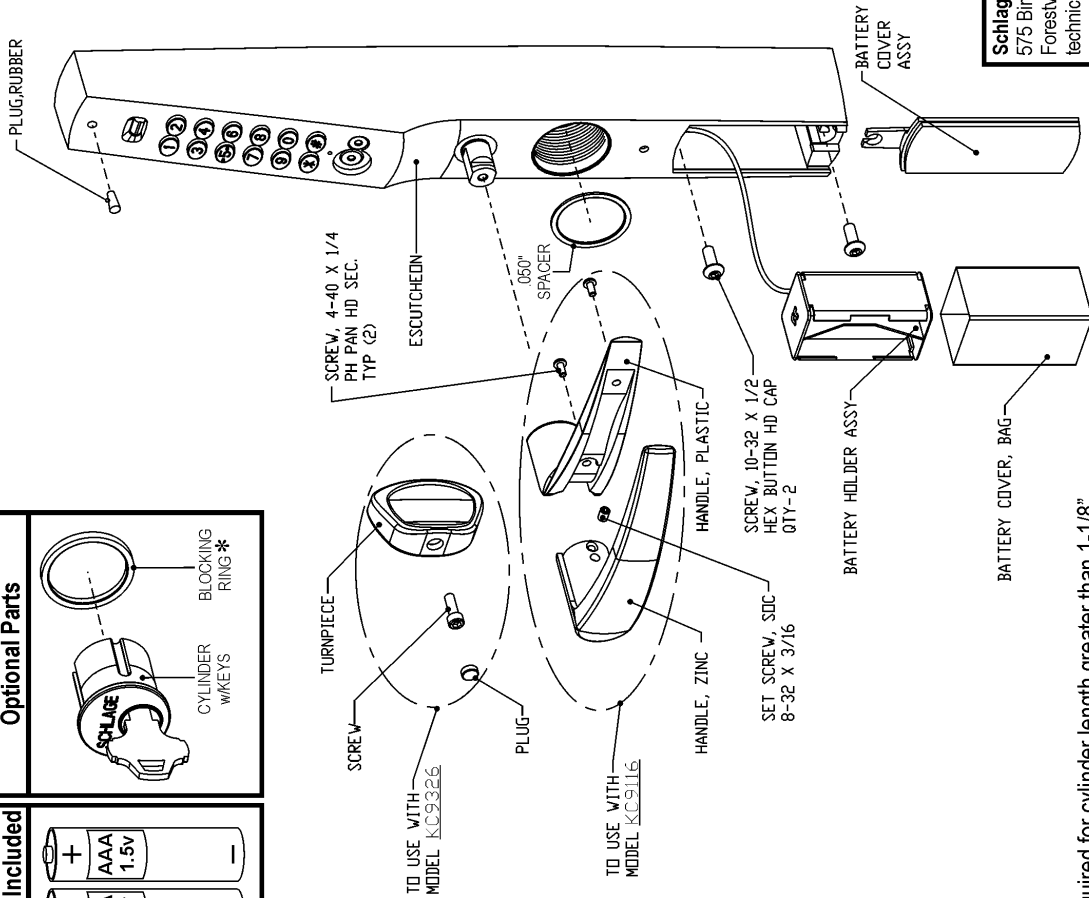

Schlage Lock Company
 575 Birch Street
 Forestville, CT 06010
 Technical support: 866-322-1237
 fax: 866-322-1233
 web: <http://www.irsupport.net>

* Blocking Ring required for cylinder length greater than 1-1/8"
 (Blocking Ring thickness = cylinder length minus 1-1/8")

KC918A/KC918A-2, KC938A/KC938A-2 INSTALLATION

Introduction / Tools and Materials Needed / Contact Info

Introduction:

The KC918A/KC918A-2 and KC938A/KC938A-2 are designed for use with 995 MF Multi-Function NS mortise locks. The trim will retract the latch when an access code or iButton is entered and the lever is depressed or the turnpiece is turned. Mechanical key override is standard. When a 'toggle' code or iButton is entered the lever or turnpiece will be continuously engaged allowing latched passage mode until a 'toggle' code or iButton is entered again to relock the trim.

KC918A/KC918A-2 is trim w/lever.

KC938A/KC938A-2 is trim w/turnpiece.

Tools and Materials Needed:

1. Flat head screwdriver w/straight, 1/8" wide blade
2. Small Philips head screwdriver
3. 1/16" Allen wrench
4. Long nose needle-nose pliers
5. Center punch
6. Hammer
7. Power drill
8. 19/32" drill bit
9. 1/4" drill bit
10. Jig saw w/blade
11. Drill & Tap for 10-32 threads

Contact Information:

Schlage Lock Company
575 Birch Street
Forestville, CT 06010
technical support: 866-322-1237
fax: 866-322-1233
web: <http://www.irsupport.net>

KC918A/KC918A-2, KC938A/KC938A-2 INSTALLATION

Door Preparation

Door Conditions:

Installation may require the use of a cover plate (a) to cover the holes left in the door. If the KC9321 (trim w/turnpiece) is used and the existing pull (b) must be removed, Ives offers a compatible pull.

- >Schlage Cover Plate P/N: KC9000-KRP
- >Ives Pull P/N: 8190-18-xxx (xxx = finish)

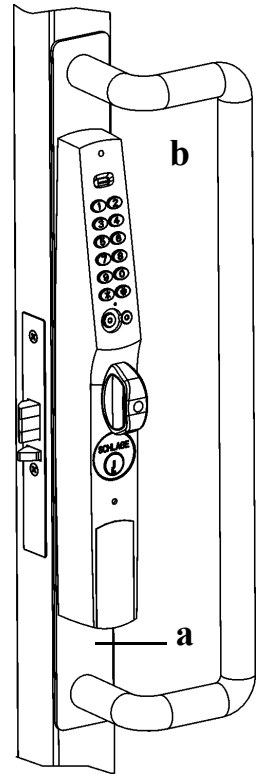
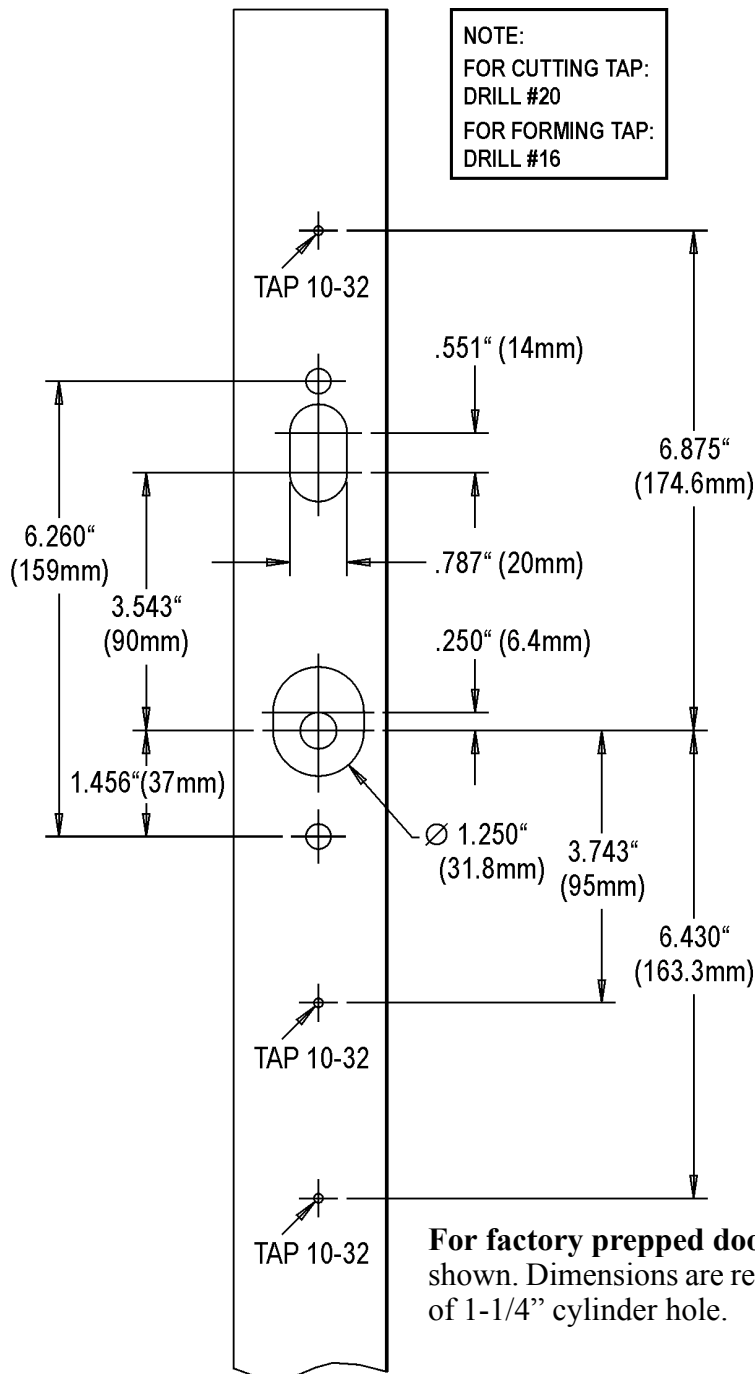

KC918A/KC918A-2, KC938A/KC938A-2 INSTALLATION

Cams, Cores, Cylinders and Blocking Rings

Cams For Mechanical Override Cylinder:

The KC9000 trim requires the use of a clover leaf cam (a). This is a list of compatible Schlage parts. For other manufacturers, consult cross-reference charts.

- > Cam for Standard Mortise cylinder: Schlage Everest: L583-153
Schlage Classic: L583-254
- > Cam for Interchangeable Core: Schlage IC Cam: L583-255

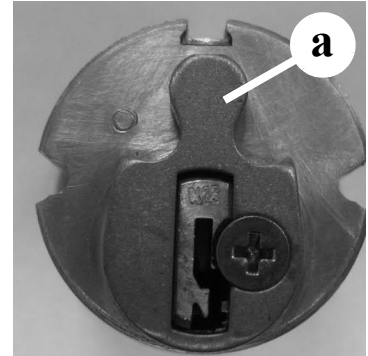

IC Cores:

- > Small Format IC core w/ cam: Schlage: 80-108-<FINISH>
NOTE: This core requires the use of 1/4" blocking ring:
Schlage: 36-079-025-<FINISH>



- > Full Size IC core w/ cam: Schlage: 30-016-<FINISH>
NOTE: This core requires the use of 3/8" blocking ring:
Schlage: 36-079-037-<FINISH>



Cylinders / Blocking Rings:

The KC9000 can use a 1-1/8" mortise cylinder without the use of a blocking ring. For cylinders longer than 1-1/8" a blocking ring is required. The blocking ring thickness is equal to the cylinder length, minus 1-1/8". For example, if you use a 1-1/2" cylinder you need a 3/8" blocking ring. Compression rings can be ordered from a Schlage distributor:

	Thickness:	Schlage Part Number:
No compression ring:	1/8"	36-079-012-<FINISH>
	1/4"	36-079-025-<FINISH>
	3/8"	36-079-037-<FINISH>
	1/2"	36-079-050-<FINISH>



KC918A/KC918A-2, KC938A/KC938A-2 INSTALLATION

Installing the KC918A/KC918A-2 or KC938A/KC938A-2

Installing the KC918A/KC918A-2 or KC938A/KC938A-2

If your trim has a key cylinder already installed, skip to **Determine Hand: on page 12**. Otherwise, continue with **Loosen the Baseplate Screws: on this page**.

1) Loosen the Baseplate Screws:

IMPORTANT: Do not remove any of the screws in the following step or it will be difficult to reinstall them.

- Using a small Philips head screwdriver, **loosen** screws **a** & **b** in baseplate, around key cylinder hole, **one turn**.

NOTE: Screws a, b, c & d are set at the factory.

Screws a & b are tightened and screws c & d are left loose.

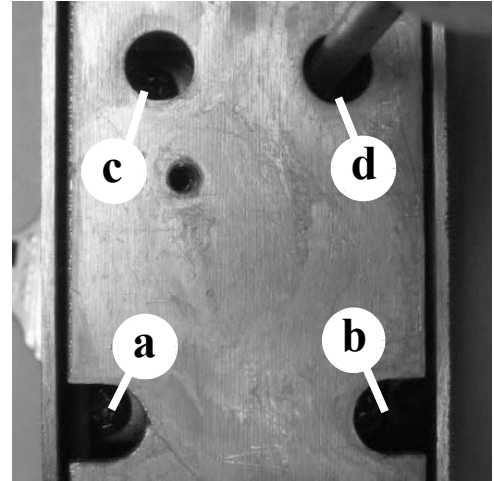

2) A Key Cylinder That Is At Least 1-1/8" Long Must Be Installed:

- > The key cylinder that you install must be 1-1/8" long or longer.
- >>>> **Do not attempt to install a key cylinder that is shorter than 1-1/8"**
- > The two illustrations below show the difference between a 1" and a 1-1/8" key cylinder.

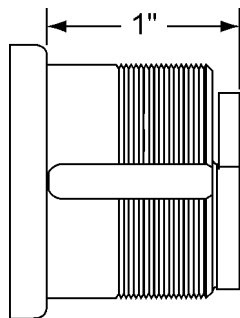

1" long key cylinder.

DO NOT ATTEMPT TO INSTALL A 1" LONG KEY CYLINDER.

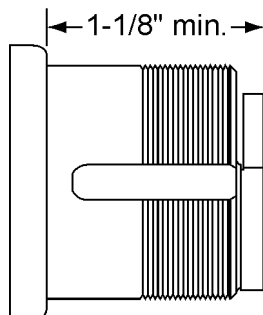

1-1/8" long key cylinder

ONLY INSTALL A KEY CYLINDER THAT IS AT LEAST 1-1/8" LONG.

KC918A/KC918A-2, KC938A/KC938A-2 INSTALLATION

Installing the KC918A/KC918A-2 or KC938A/KC938A-2

3) Make Room for Key Cylinder:

Due to the diameter of the key cylinder, it is necessary to have dead latch (a) placed out of the way when installing the key cylinder. Therefore...

- Using your finger or a pair of needle-nose pliers, push dead latch towards the top end of trim as indicated by arrow in photo.

NOTE: As indicated by arrow in photo, you'll notice that when you push the dead latch forward, it will swing a little bit in a counterclockwise direction.

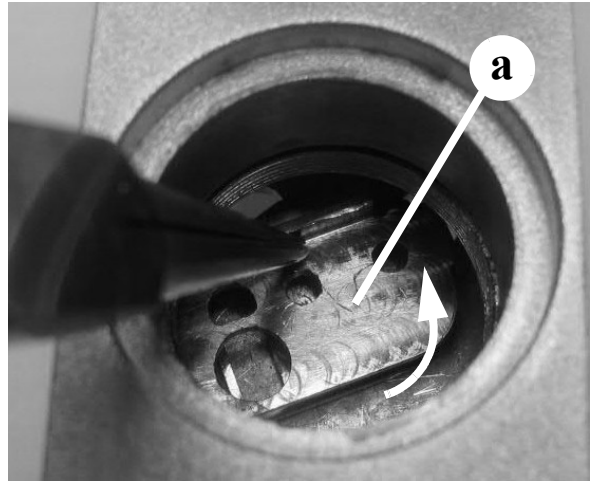

4) Hold Dead Latch in Place:

To insure that dead latch is placed far enough out of the way to allow key cylinder to be threaded in properly:

- Insert a finger into key cylinder hole and hold dead latch firmly in place.
- Carefully turn the trim over while keeping the dead latch in position.



5) Verify Placement of Dead Latch:

Two holes on dead latch (a) should be showing within the two holes (b) in baseplate.

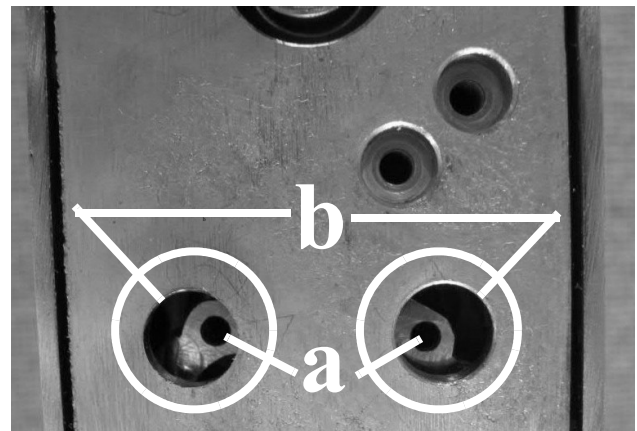

KC918A/KC918A-2, KC938A/KC938A-2 INSTALLATION

Installing the KC918A/KC918A-2 or KC938A/KC938A-2

6) Install the Key Cylinder:

- Install .050" cylinder washer.

IMPORTANT: A .050" cylinder washer must be used **IN ALL CASES**, regardless of the key cylinder length.

- If you are installing a cylinder that is longer than 1-1/8", you must also install a blocking ring (see **Table 1: Blocking Rings, on page 8**).

A simple formula for determining blocking ring thickness is:
Blocking ring thickness = length of cylinder minus 1-1/8"

- If not already done, install cam onto cylinder. Cam must be clover leaf design (see **Table 2: Recommended Cams, on page 8**).
- Tilt top of trim down at a sharp angle.
- Screw in key cylinder until it stops. Use mechanical key as a handle for turning if necessary.



Table 1: Blocking Rings

Key Cylinder Length	Blocking Ring (Schlage P/N; XXX = finish)
• 1-1/4"	1/8" (36-079-012-XXX)
• 1-3/8"	1/4" (36-079-025-XXX)
• 1-1/2"	3/8" (36-079-037-XXX)
• 1-5/8"	1/2" (36-079-050-XXX)

Table 2: Recommended Cams

Cylinder/Core	Schlage Type	Part Number
• Standard Mortise Cyl	Everest	L583-153
• Standard Mortise Cyl	Classic	L583-254
• Interchangeable Core	IC Cam	L583-255

7) Align Key Cylinder:

- After screwing it all the way in, back off on key cylinder (no more than one turn) until key is at the bottom. If key cylinder has a logo (a), logo should be at the top of key cylinder.

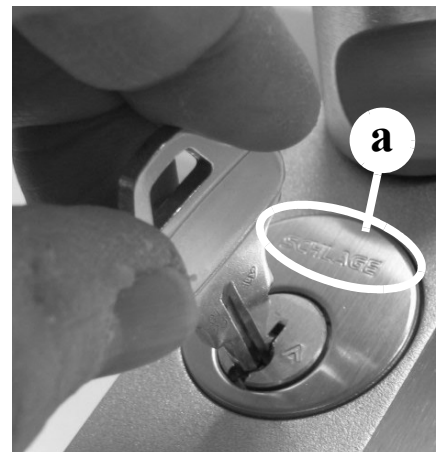

KC918A/KC918A-2, KC938A/KC938A-2 INSTALLATION

Installing the KC918A/KC918A-2 or KC938A/KC938A-2

8) Alignment of Interchangeable Cores:

- If an IC Core is used, center the interface toward the bottom.



9) Tighten the Four Screws in the Baseplate:

- Tighten the four baseplate screws in the following order:
 - > Tighten **a** and **b** until snug.
 - > Tighten **c** and **d** until snug.
 - > Fully tighten **a** and **b**.
 - > Fully tighten **c** and **d**.
 - > Check all four screws to make sure that all four are completely tight.

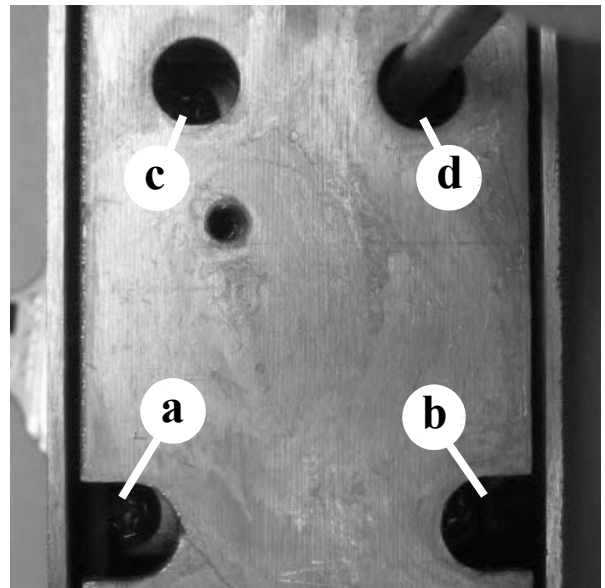

10) The Dead Latch's "Critical Edge:"

- For clarity purposes only, photo on the right is a view of deadlatch with escutcheon removed.
- Edge (**a**) is referred to as the dead latch's "critical edge."

IMPORTANT: In the next step, the "critical edge" on deadlatch will have to be lined up with hole (**b**) in baseplate. See Position the Dead Latch's Set Screw Hole: on page 10

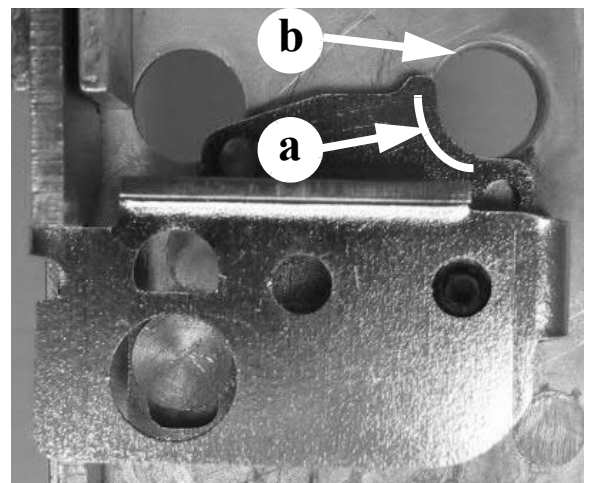

KC918A/KC918A-2, KC938A/KC938A-2 INSTALLATION

Installing the KC918A/KC918A-2 or KC938A/KC938A-2

11) Position the Dead Latch's Set Screw Hole:

- Tilt the trim until you see the “critical edge” align with the larger hole in the baseplate as shown in photo on right. Look closely at edge of dead latch’s “critical edge” (a) when doing this.

IMPORTANT: When the dead latch’s “critical edge” is correctly aligned, the dead latch’s set screw hole will likewise be correctly aligned.

Photos A, B and C below illustrate examples of an incorrectly aligned critical edge. Photo D is an example of a correctly aligned critical edge.

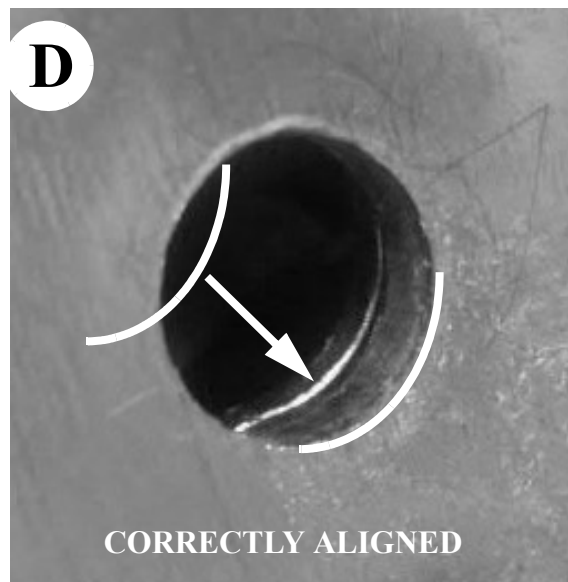
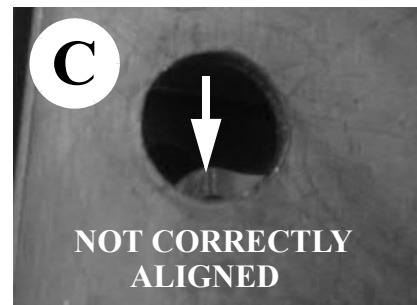
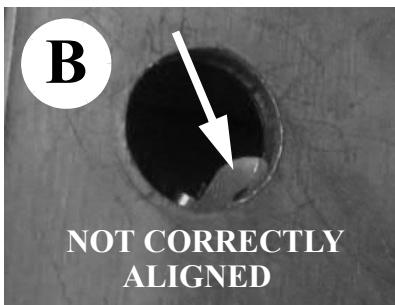
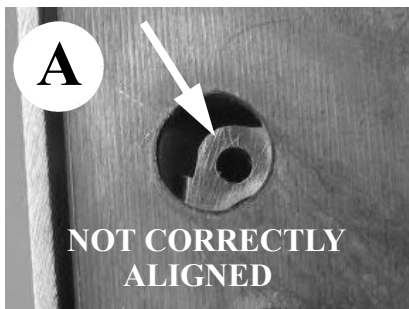
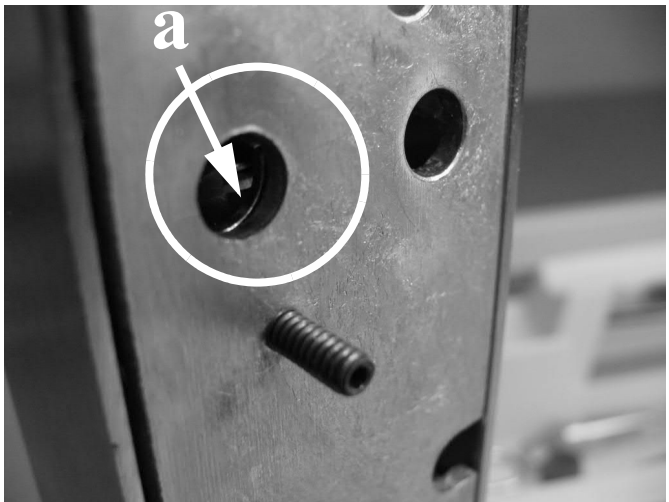

KC918A/KC918A-2, KC938A/KC938A-2 INSTALLATION

Installing the KC918A/KC918A-2 or KC938A/KC938A-2

12) Partially Tighten the Set Screw:

- Using a 1/16" Allen wrench, partially turn in the set screw until outer end of set screw is about flush with surface of baseplate.



13) Fully Tighten the Set Screw:

- Finish turning in the set screw until it hits the stop.

IMPORTANT: At this time, outer end of set screw should be a little bit below the surface of the baseplate, as shown in photo A. If you have turned in set screw as far as it will go and it is protruding beyond the surface of baseplate, as shown in photo B, the most probable cause is that dead latch was not positioned properly (see Position the Dead Latch's Set Screw Hole: on page 10).

If you have turned the set screw in as far as it will go and it is protruding from the surface of the baseplate, do the following:

- Turn set screw back out so that about 1/4" is protruding from surface of baseplate.
- Reposition critical edge on dead latch according to the instructions on page 10).
- Turn set screw in until it **just hits the stop**.

IMPORTANT: Do not overtighten set screw because the baseplate may start to bow outward resulting in a gap between trim and door when trim is mounted.

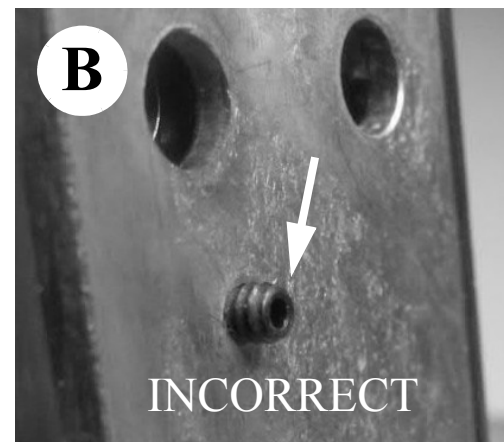
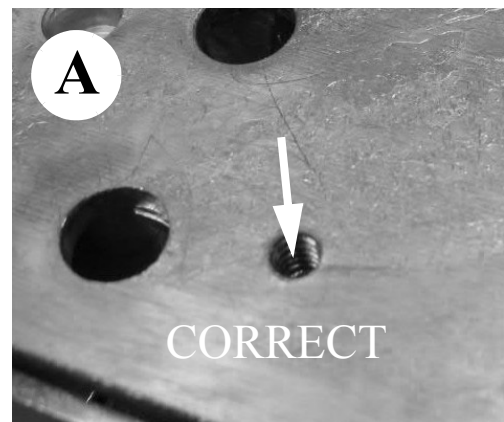

KC918A/KC918A-2, KC938A/KC938A-2 INSTALLATION

Installing the KC918A/KC918A-2 or KC938A/KC938A-2

14) Determine Hand:

To determine hand:

- Stand on outside of door.
- Determine which arm the hinges are closest to.
- If door is pulled to open, it is "Reverse."

NOTE: All narrow stile trim is "Reverse."

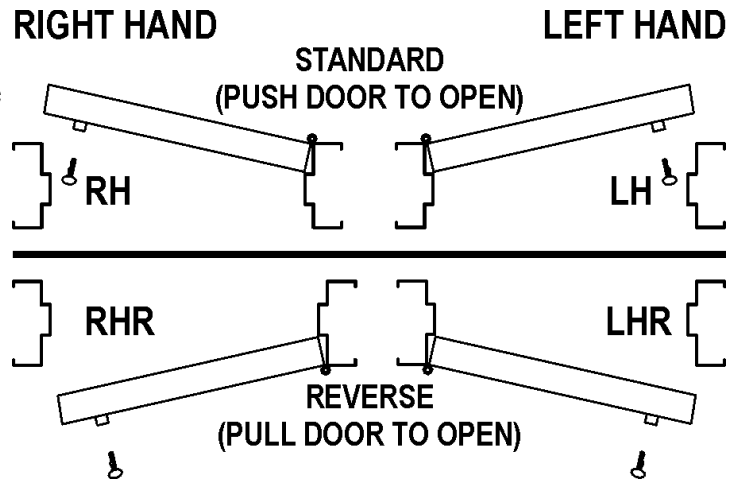

15) Verify Lever / Turnpiece Stop Screw Direction:

Once the handing of the installation is determined, you may have to change the location of the stop screw in the baseplate.

To change the location of the stop screw:

- Use a 3/32" Allen wrench.
- For RHR installations:
 - > Refer to photo on the right for stop screw location (a).
- For LHR installations:
 - > Refer to photo on the right for stop screw location (b) for LHR.

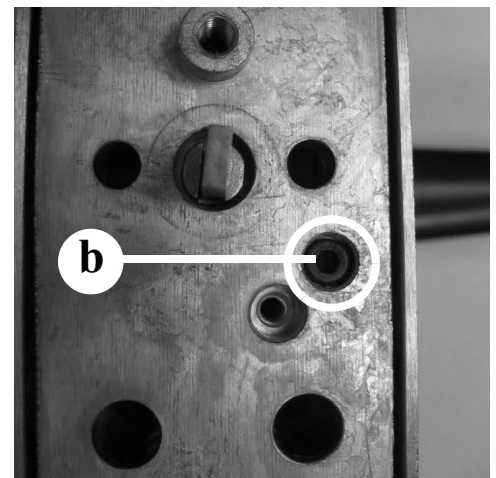
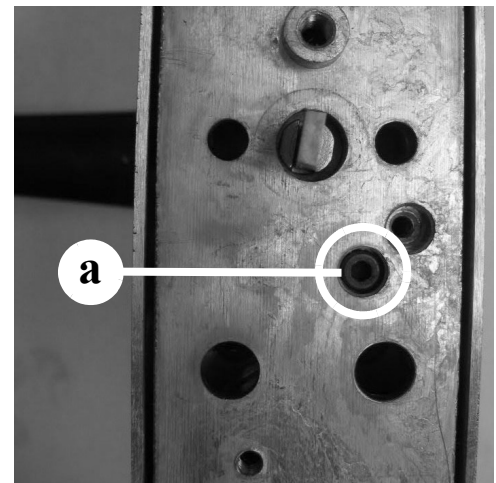

IMPORTANT: Stop screw must be set for proper rotation. This applies to both lever and turnpiece models.

KC918A/KC918A-2, KC938A/KC938A-2 INSTALLATION

Cams, Cores, Cylinders and Blocking Rings

If you are installing a KC918A, continue with, **Install the Lever: on page 13**. Otherwise, skip to, **Insert the Mortise Into the Door Stile: on page 14**.

16) Install the Lever:

- Determine correct orientation for door and lock hand and slide lever onto shaft accordingly.

NOTE: *A RHR installation is shown in the photo on the right.*

- Using a 5/64" hex wrench, tighten the set screw.

IMPORTANT: *After set screw has been completely tightened, top of set screw should be at or a little bit below surface of lever. If not, check to insure that lever is pushed completely over shaft.*

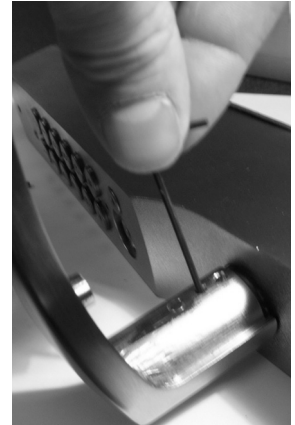

17) Install the Lever Cover:

- Place lever cover onto inside of lever.



18) Secure the Lever Cover:

- Secure lever cover with two Phillips head screws.



KC918A/KC918A-2, KC938A/KC938A-2 INSTALLATION

Cams, Cores, Cylinders and Blocking Rings

19) Insert the Mortise Into the Door Stile:

- Holding the mortise latch as shown, insert it into the slot in the edge of the door stile.



20) Partially Tighten the Mortise Mount Screws:

- Partially tighten the two screws (a & b) to secure the mortise in place.

NOTE: Do not fully tighten these two screws. Leave them loose for now.



21) Prepare the Exterior Gasket:

- Peel paper backing off of exterior gasket (a).

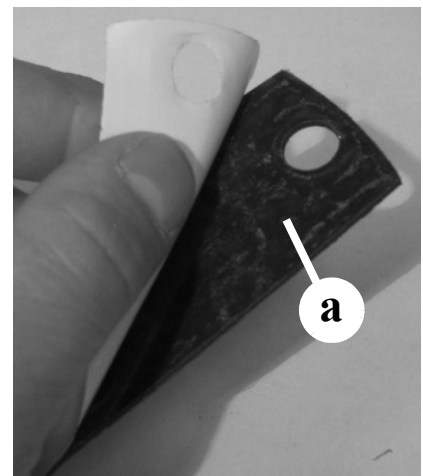

KC918A/KC918A-2, KC938A/KC938A-2 INSTALLATION

Cams, Cores, Cylinders and Blocking Rings

22) Apply the Exterior Gasket:

- Apply gasket to back of trim.

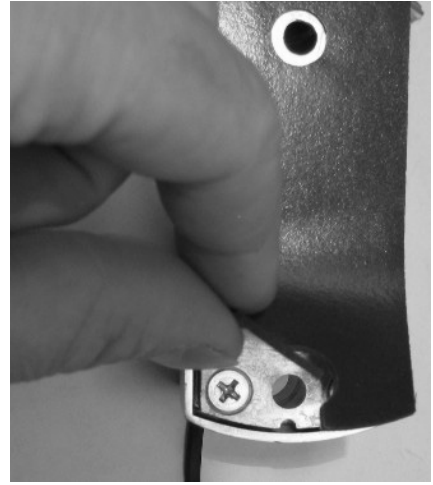

23) Check the Trim's Gasket:

- Before you place the trim against the door stile, refer to photo and verify that you've applied the gasket properly.



24) :

- Carefully line up parts for engagement and place trim against door.
- NOTE: Turning the lever may be necessary for proper engagement.**



KC918A/KC918A-2, KC938A/KC938A-2 INSTALLATION

Cams, Cores, Cylinders and Blocking Rings

25) Tighten Top Mounting Screw:

- Using a ball-end, 1/8" Allen wrench, partially tighten the top screw in trim.

IMPORTANT: Do not completely tighten the top screw. Leave loose for now.

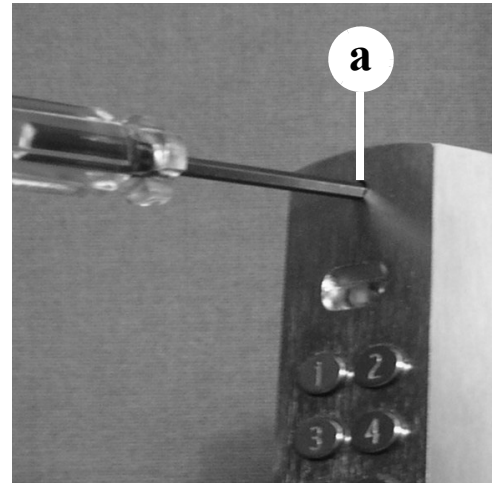

26) Install the Spindle and Spring:

- Insert the spindle and spring into the inside face of stile.



27) Install the Inside Escutcheon:

- Place the inside escutcheon against the inside of the door.

NOTE: Make sure that the spindle and spring insert themselves into the lever pivot opening.

- Secure in place with the two screws provided.



KC918A/KC918A-2, KC938A/KC938A-2 INSTALLATION

Cams, Cores, Cylinders and Blocking Rings

28) Remove Battery Cover:

- If not already done, insert key into cylinder and turn it counterclockwise.
- Using a small, flat blade screwdriver, loosen the battery cover screw (a) **ONLY TWO TURNS COUNTERCLOCKWISE**.
- Slide off battery cover (b) from bottom.
- Pull out battery pack from battery compartment. Battery pack is attached to a wire harness.

IMPORTANT: Do not cut or attempt to remove the battery pack's wire harness.

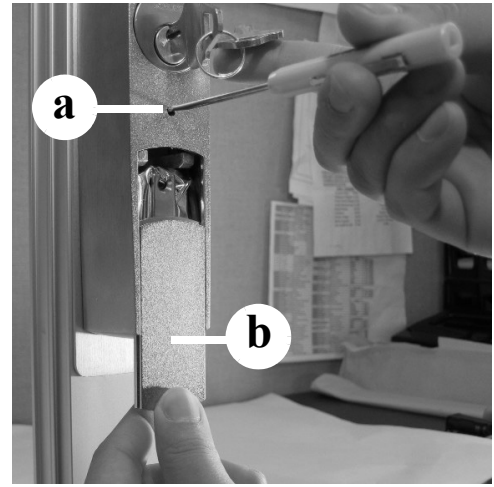

29) Install Lower Mounting Screws:

- Remove battery pack (a).
- Install and completely tighten both lower mounting screws (b) and (c) located within battery compartment.
- Finish tightening top mounting screw.

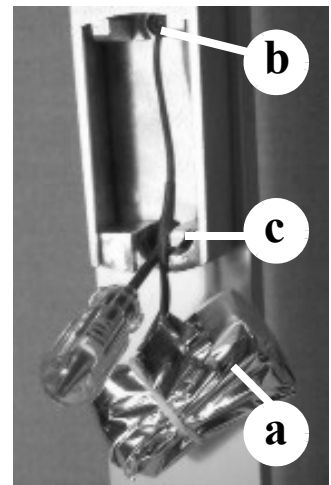

30) Install Batteries:

- Remove and retain battery bag.

IMPORTANT: DO NOT DISCARD BATTERY BAG. IT IS IMPORTANT THAT IT IS REINSTALLED AFTER THE BATTERIES ARE INSTALLED IN BATTERY HOLDER.

- Observe the polarity markings indicated on battery holder and install four, AAA batteries accordingly.
- Slide battery bag onto battery holder.



KC918A/KC918A-2, KC938A/KC938A-2 INSTALLATION

Cams, Cores, Cylinders and Blocking Rings

31) Fold Battery Bag:

- Fold battery bag over.

IMPORTANT: *The battery bag is used to protect the batteries from moisture and to insulate them electrically from metallic parts.*



32) Install Battery Pack:

- Install battery pack into compartment with bag opening facing down.
- Tuck wiring neatly into compartment

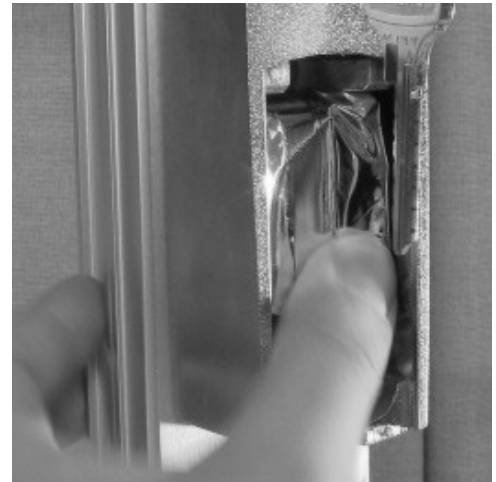

33) Install Battery Compartment Cover:

- Slide battery compartment cover on from the bottom.

IMPORTANT: *Use caution not to pinch the battery wires.*

- Tighten battery cover screw.
- Rotate key clockwise.
- Remove key.



KC918A/KC918A-2, KC938A/KC938A-2 INSTALLATION

Cams, Cores, Cylinders and Blocking Rings

34) Install the Armor Front:

- Completely tighten the two screws that secure the mortise to the inside of the door stile.
- Place armor front over mortise.
- Secure armor front in place with two screws provided.



35) Install Water Plug.

- Insert water plug (a) into top mounting screw hole.
- Using the end of a small Allen wrench or similar tool, push plug into hole past surface.

INSTALLATION COMPLETE

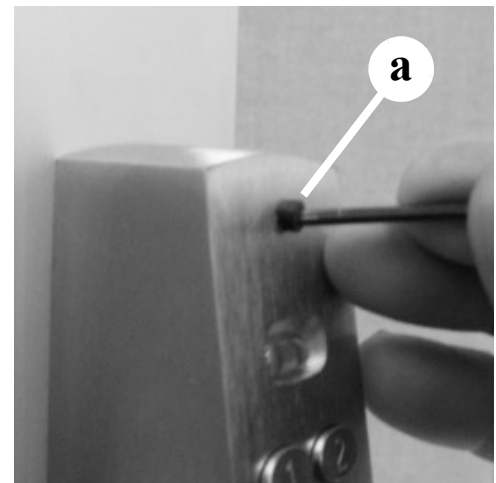

KC918A/KC918A-2, KC938A/KC938A-2 INSTALLATION

Test Operation / Dimensions

Test Operation

1. Lever should be able to be pushed down, but not up.
2. Turnpiece should rotate clockwise for RHR and counterclockwise for LHR.
 - > If you find that this is not correct, see, **Verify Lever / Turnpiece Stop Screw Direction: on page 12.**
3. Insert key into cylinder and rotate it counterclockwise.
 - > Lever/turnpiece should retract latch.
 - > The key should only rotate counterclockwise, not clockwise.
 - > If you find that this is not correct, see, **Partially Tighten the Set Screw: on page 11.**
4. Rotate key back to original position and remove it.
 - > Lever/turnpiece should no longer retract latch.
5. Using the keypad, enter the default access code: 1 3 5 7 9.
 - The red LED should light each time the first four numbers are pressed and when the 9 is pressed, the green LED should flash for five seconds during which time the lever/turnpiece should retract the latch.
6. Test exit device to make sure it is operating properly.

SEE PROGRAMMING GUIDE FOR PROGRAMMING INFORMATION.

Dimensions

